

DIN 319-NI

Ball knobs

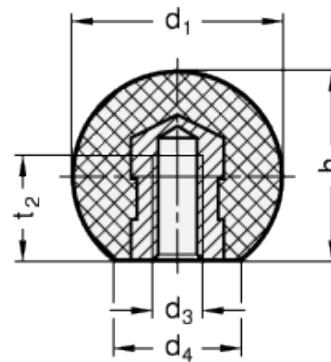

INOX
Stainless Steel

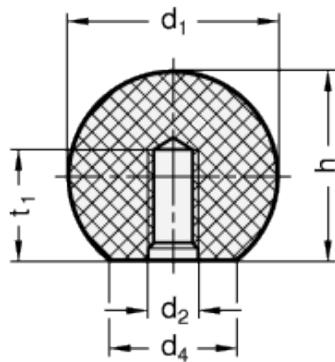

technical informations

Material

AISI 303 stainless steel, shot-blasted matte finish.

Standard versions available

- Version B: Tapped blind hole.
- Version K: with plain hole H7.

Standard Elements	Main dimensions			Mounting hole				Weight
	d ₁	d ₄	h	d ₂	d ₃ H7	t ₁ min.	t ₂ min.	
DIN 319-NI-16-M4-C	16	8	15	M4	-	7	-	16
DIN 319-NI-16-B6-K	16	8	15	-	B6	-	9	15
DIN 319-NI-20-M5-C	20	12	18	M5	-	9	-	31
DIN 319-NI-20-B8-K	20	12	18	-	B8	-	11	25
DIN 319-NI-25-M6-C	25	15	22.5	M6	-	11	-	89
DIN 319-NI-25-B10-K	25	15	22.5	-	B10	-	14	75

DIN 319-NI-32-M8-C	32	18	29	M8	-	14.5	-	122
DIN 319-NI-32-B12-K	32	18	29	-	B12	-	17	115
DIN 319-NI-40-M10-C	40	22	37	M10	-	18	-	241
DIN 319-NI-40-B16-K	40	22	37	-	B16	-	22	230
DIN 319-NI-50-B20-K	50	27	46	-	B20	-	28	384



STANDARD MACHINE ELEMENTS WORLDWIDE